

B 
NIK

RULES

CONTENTS

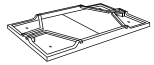

1 BONK board



4 Chutes



12 Steel balls



1 Wooden goal ball

INTRODUCTION

BONK, the fast rolling ricochet game, will give you and your friends hours of entertainment. We congratulate you on a wise investment. The aim of the game is to roll steel balls down your chute(s) so as to knock the wooden ball into your opponents' goal. BONK demands a good eye, timing, and teamwork. It penalises both fumbling and trigger-happy play.

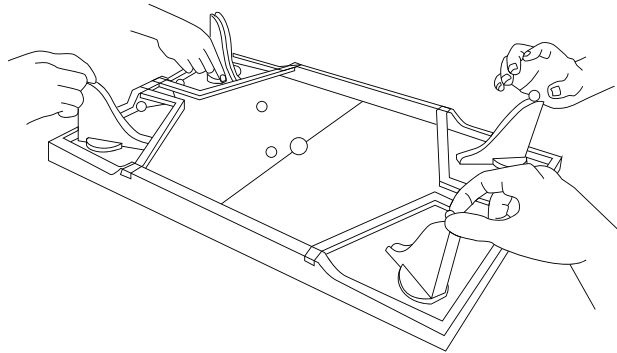

SETTING UP THE GAME

- 1 Place the board on a level surface
- 2 Put the chutes on their places in each corner
- 3 Place 3 steel balls in each corner
- 4 Balance the wooden goal ball on the starting dot in the middle of the board.

HOW TO PLAY

- 1 BONK plays best with four people (two teams of two), Take up your positions with one team at each end and each player controlling one of the chutes.
- 2 Every match and each point starts with a "high five". Players clap their hands simultaneously with the person on their both sides. If you want to add some energy around the table we suggest yelling BONK at the same time.
- 3 Roll steel balls down your chute(s), aiming to knock the wooden ball into your opponents' goal.
- 4 After one side has scored move the scoring marker on the scoring track (always go from left to right) and replace the wooden ball on the starting dot. Teammates can re-distribute steel balls between them, but no steel balls should be passed to the other side, unless the other side is completely out steel balls, in this case they receive one ball - known as the silver bullet - from the other side. The next round begins with a high five as before.
- 5 The winners are the first to score 5 points.

TO CLARIFY

- When high fiving your mates, you need to have empty hands. So don't try to get a head start by hiding steel balls in your hands.
- You can only pick up steel balls from behind the goal barriers at your end. You are allowed to pass balls to your partner, or take some of theirs.
- A goal is only counted once the ball hits the "nose" at the back of the goal.

TWO PLAYER GAME

Singles games are great fun for more accomplished players. Two player rules are just the same as in team play, except one player is in charge of both of the chutes on his side. However, you might want to focus on using just one chute at a time.

CANNONBALL RULES

This is a funny variation which adds a new layer of mayhem, especially for two player games. Under Cannonball rules you can score in two ways: the normal way by hitting the goal ball into the goal OR by getting all the silver balls on the other half of the board and crying "Cannonbaaaaall!". After a Cannonball point, redistribute the metal balls – 3 in each corner.

BASIC TACTICS

Skim The Milk

The wooden ball often perches next to the goal, this is called a lark's breakfast. If it happens at your end, the best response is to skim the milk by aiming just behind the ball. Ambitious players may prefer the Depardieu, where you rebound off the nose as shown above. Meanwhile, the other team will be aiming for a full-fat-a hole-in-one shot to turn the lark's breakfast into a goal.

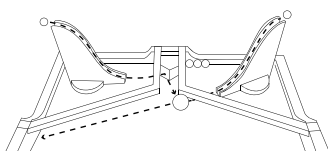

Attacking and Defending

Skilful BONK play requires a careful balance between aggression and defence. Machine gun firing rates will leave you with no balls! Whereas careful skimming of the milk will often knock the goal ball over the other side whilst your steel ball rolls back to you.

LOOKING AFTER YOUR GAME

Your BONK game is a precision instrument. Please keep it away from extreme temperatures, and on no account get it wet.